

MINOLTA

VECTIS

WEATHERMATIC

ZOOM

E INSTRUCTION MANUAL



ADVANTAGES...

OF THE ADVANCED PHOTO SYSTEM

Thank you for purchasing the Minolta Vectis Weathermatic. The Vectis Weathermatic is a water resistant Advanced Photo System™ camera designed to take pictures anywhere you go. Its housing is sealed to prevent entry of moisture and dust, so you can enjoy taking pictures on the ski slope, at the beach, or even underwater (approx. 10m (33 ft.)).

Your camera has been designed to be water resistant when used as described in the manual. Careless handling however, may allow water to enter the camera causing permanent damage to internal parts. To obtain the best performance from your camera, read the instruction manual thoroughly.

- Advanced Photo System™ is a trademark of the five system developing companies.

New print formats...

Classic C print, wider H print, and panorama P print formats are available with Advanced Photo System cameras.

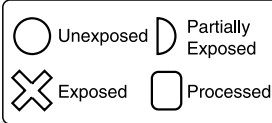
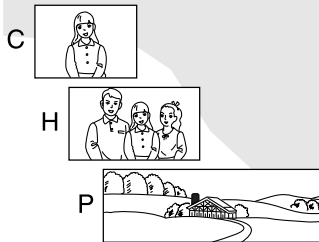

Easier to load...

Advanced Photo System cameras use the new IX240 type film. This new film features drop-in-loading to make loading your camera simple, the first time, every time. Indicators on the top of the cassette tell you if the film is unexposed, partially exposed, exposed, or processed.

New processing....

In addition to returning your prints in the format you selected, certified photofinishers will return your Advanced Photo System film in its original cassette with an index print. To order reprints, simply choose the images you want from the index print. No more searching through negatives to find the right frame.

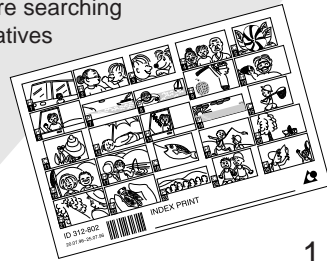

TABLE OF CONTENTS

For Proper and Safe Use	4
Using In/Around Water	6
Operating Conditions	12
Names of Parts	14
Attaching and Removing the Strap	17
Installing the Battery	18
Loading Film	21

Taking Pictures	25
Taking Pictures Underwater	28
For Closer Subjects	29
Special Focus Situations	30
Focus Hold	32
Using the Built-in Flash	
Red-eye Reduction	36
Manual Fill-Flash	37
Flash Cancel	37
Night Portrait	38
Rewinding the Film	
Auto Rewind	39
Manual Rewind	40

Date Imprinting	
Imprinting the Date or Time	41
Setting the Date and Time	42
Changing the Date/Time Format	44
Self-Timer	46
Caring for your Camera	48
Lab Services	50
Specifications	52

FOR PROPER AND SAFE USE

Read and understand all cautions and warnings before using this product.

WARNING

Batteries may become hot or explode due to improper use.

- Use only the battery specified in this instruction manual.
- Do not install the battery with the polarity (+/-) reversed.
- Do not subject the battery to fire or high temperatures.
- Do not attempt to recharge, short, or disassemble.

Use caution, accidents may occur when using this product near young children.

Keep batteries and other things that could be swallowed away from young children. Contact a doctor immediately if an object is swallowed.

FOR PROPER AND SAFE USE

Immediately remove the battery and discontinue use if...

- the camera is dropped or subjected to an impact in which the interior is exposed.
- the camera emits a strange smell, heat, or smoke.

Do not disassemble. Electric shock may occur if a high voltage circuit inside the camera is touched. Take your camera to a Minolta Service Facility when repairs are required.

USING IN/AROUND WATER

This camera is water resistant and can be used in the rain, snow, or underwater to a depth of approx. 10 meters (33 ft.). However, careless handling may cause irreparable damage not covered by the warranty.

Please observe the following cautions:

- Do not hold the camera under running water.

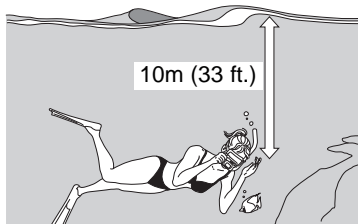
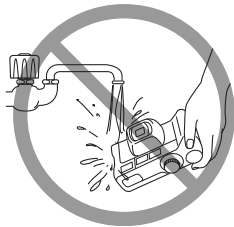

- Do not take the camera to depths greater than 10m (33 ft.).

USING IN/AROUND WATER

- Do not jump or dive into the water while holding the camera.



- Do not surf with the camera.

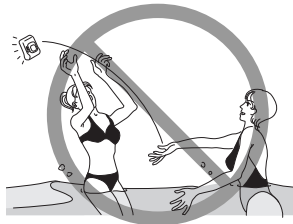

- Do not throw the camera.

USING IN/AROUND WATER

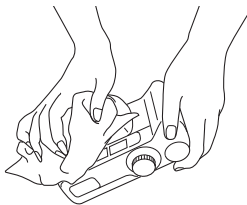

- Clean and dry the camera before opening the film and battery chambers.
- Do not load film or replace the battery in places where water, blowing sand, or dust can enter the camera.
- Keep hands, film, and battery clean and dry when inserting or removing the film or battery.



USING IN/AROUND WATER

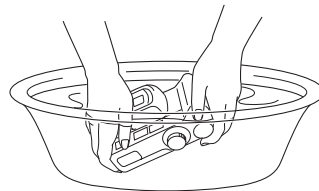

- The gaskets will be damaged if the camera is not washed in fresh water after exposure to salt water.
- The surface of the camera can be damaged if sunscreen and tanning lotions are not removed immediately.
- Clean the camera by immersing it in a small volume of fresh water.
- Do not use compressed air or a hair dryer to dry the camera.

USING IN/AROUND WATER

The interior of this camera is not water resistant.

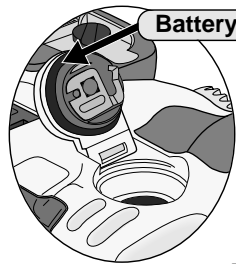

Battery Chamber Gasket

- Clean the gaskets and joining surfaces before closing covers.

- Remove foreign matter from the gaskets with a clean, dry cloth.



Film Chamber Gasket

USING IN/AROUND WATER

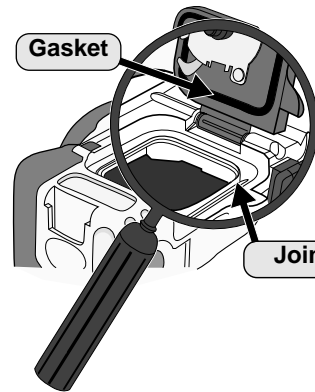

- Inspect the gaskets and joining surfaces every time the film or battery chambers are opened. If the seals are brittle, cracked, or discolored, the camera may leak. Contact an authorized Minolta Service Facility to have the gaskets replaced.

- Make sure the covers close tightly.

OPERATING CONDITIONS

OPERATING CONDITIONS

- This camera is designed for use from -10 to 40 °C (14 to 104 °F).
- Never leave your camera where it may be subjected to extreme temperatures such as inside the glove compartment of a car.
- At colder temperatures, the data panel response time will be slow. At higher temperatures, the display may temporarily darken, but will restore when the temperature normalizes.
- To prevent condensation from forming inside the camera when bringing the camera from an extremely cold area to a warm area, let the camera come to room temperature before opening the film or battery chambers.
- When photographing in cold weather, keep the camera and spare batteries inside your coat to keep them warm when you are not shooting. Cold batteries will regain some of their charge when they warm up.

OPERATING CONDITIONS

FILM CASSETTE WARNING

The film used in Advanced Photo System cameras stores some data magnetically. Do not place the film cassette on or near anything that creates a magnetic field, such as a television or stereo speakers.

CAMERA ERROR

If the camera will not function with a fresh battery, remove the battery, wait a few minutes, then reinsert it. If normal operation does not resume or the camera malfunctions repeatedly, contact an authorized Minolta Service Facility.

NAMES OF PARTS

Body

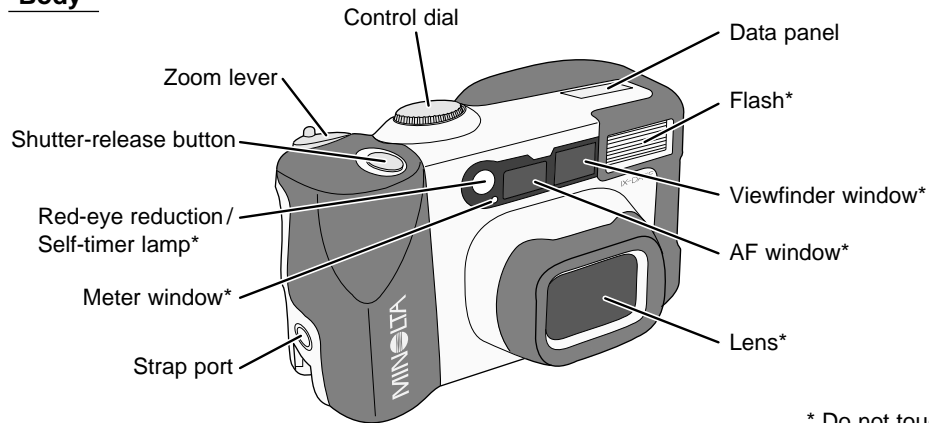

* Do not touch

NAMES OF PARTS

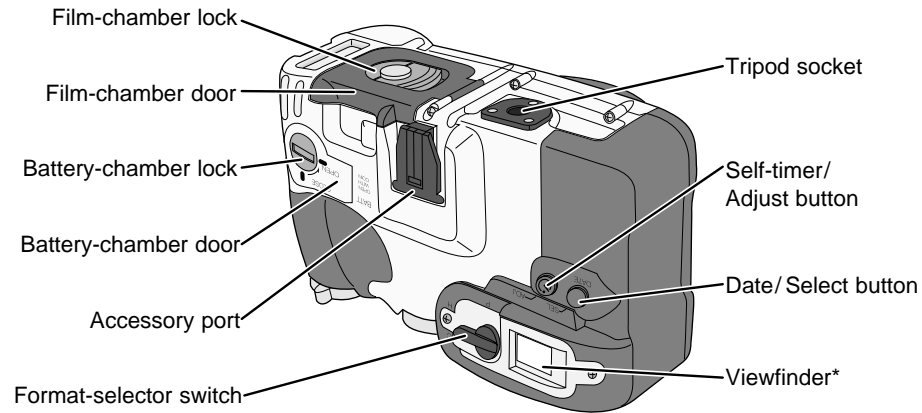

NAMES OF PARTS

Data Panel

Date/Time display

Frame counter



Cassette mark

Self-timer indicator

Battery warning

Viewfinder

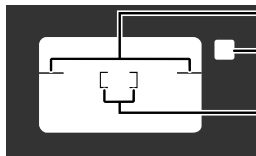

Close-framing guides

Ready lamp

Focus frame

Ready Lamp Signals

Glowing	Flash is charged.
Blinking Rapidly	Subject too close. Shutter is locked.
Blinking Slowly	Camera cannot determine focus distance. Focus set to ∞ (2-3m if flash is selected).

ATTACHING AND REMOVING THE STRAP

Attaching

Insert the strap tab into the strap port until it 'clicks'.

- Tug on the strap to make sure it is secure.

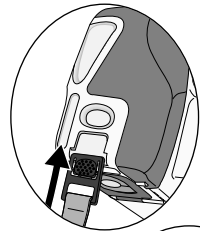

Removing

Press the strap release and pull the tab out of the strap port.

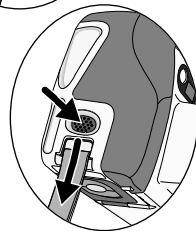

INSTALLING THE BATTERY

Your camera uses one 3-volt CR2 lithium battery to supply power for all camera operations.

Important – Before opening the Battery Chamber

- Wipe all water, sand, and grit off of the camera.
- Do not open the battery chamber in places where water, blowing sand, or dust can enter the camera.
- Make sure the battery is clean and dry before inserting it into the camera.
- To prevent condensation from forming, let the camera come to room temperature before opening the film or battery chambers when bringing the camera into a warmer environment.

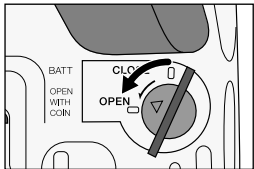

1. Using a coin or similar object, turn the battery-chamber lock to **OPEN**, then open the battery-chamber door.

INSTALLING THE BATTERY

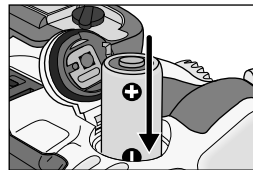

2. Insert a new battery into the chamber as indicated by the + and – marks.

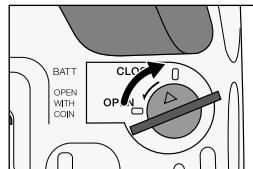

3. Close the battery-chamber door and turn the battery-chamber lock to **CLOSE**.
 - Reset the date and time after installing a new battery.

INSTALLING THE BATTERY

Battery Warning

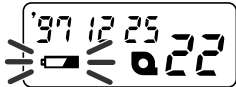

Power is low, but sufficient for all camera operations.
Keep a new battery handy.



If there is no display, replace the battery or make sure it is correctly installed.

**Your camera will shut down if it is not operated for more than 8 minutes.
Press the shutter release button partway down to restore power.**

LOADING FILM

Use IX240 (Advanced Photo System) film in this camera.

- Your camera's transport system loads the film, sets the film speed, and advances the film after each exposure.
- There is no need to worry about double exposure. DEP (Double Exposure Prevention) prevents the camera from accepting exposed film.
- Do not open the film chamber unless  appears or blinks in the data panel.

Visual Exposure Indicators (VEI)

- The current VEI has a white indicator behind it.
- Your camera can only load unexposed film (●).

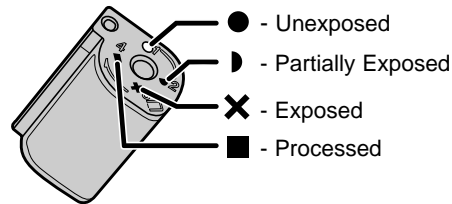

LOADING FILM

Important – Before opening the Film Chamber

- Wipe all water, sand, and grit off of the camera.
- Make sure the film cassette is clean and dry before loading it into the camera.
- Do not load film in places where water, blowing sand, or dust can enter the camera.
- To prevent condensation from forming, let the camera come to room temperature before opening the film or battery chambers when bringing the camera into a warmer environment.

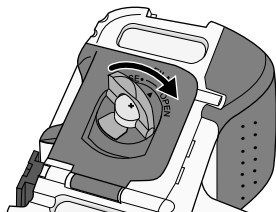

1. Turn the camera upside down. Lift the film-chamber lock and turn it to OPEN.

- The film-chamber door will unlock.

LOADING FILM

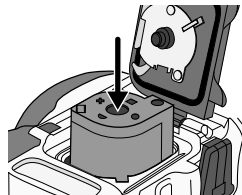

2. Open the film-chamber door and insert a new cassette into the film chamber.

- If the film-chamber door will not open, internal pressure needs to be equalized. Open the battery chamber before opening the film chamber to release the pressure.

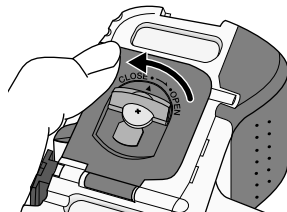







3. Press the film-chamber door closed and turn the film-chamber release to CLOSE.

- The camera will automatically advance the film to the first frame.
-  and the number of exposures remaining on the roll will be displayed in the data panel.

LOADING FILM

Film can be loaded with the power on or off.

If  blinks in the data panel, open the film chamber and remove the cassette.

- Your camera can not load a film cassette if the current VEI is , , or .
- If a processed (VEI ) or partially exposed (VEI ) cassette was loaded into this camera, the VEI has been changed to .
- If the current VEI is , reload the cassette. If the film will not load, contact the nearest authorized Minolta Service Facility.

TAKING PICTURES

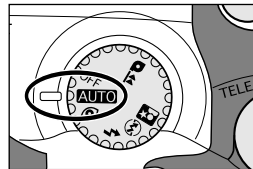

1. Turn the control dial to **AUTO**.

- The flash is set to autoflash and will fire when necessary. See page 34.

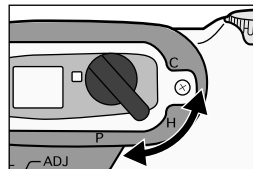

2. Select the print format.

- The viewfinder changes to match your selection.



Hold the camera steady, making sure your fingers do not cover the flash. When taking a vertically framed picture, turn the camera so the flash is on top.



Continued on following page

TAKING PICTURES

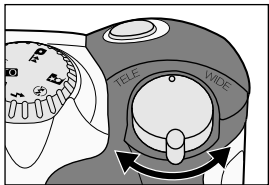

3. Looking through the viewfinder, frame the subject as desired.

Push the zoom lever to the right to zoom in.
Push the zoom lever to the left to zoom out.

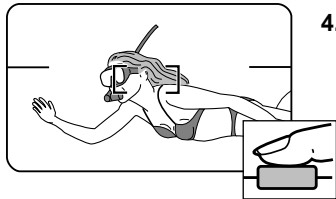

4. Center your subject in the focus frame, then press the shutter-release button partway down.

TAKING PICTURES

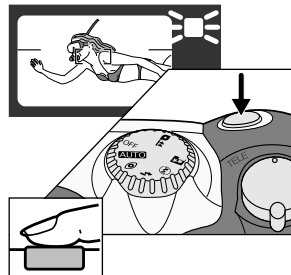

5. When the ready-lamp glows, press the shutter-release button all-the-way down to take the picture. Press the shutter with a slow steady squeeze, never a quick jab.

- The ready lamp will not glow and the shutter can not be released until the flash is charged.
- The ready lamp blinks slowly and focus is set to infinity (2-3m depending on the focal length when flash is selected) when the camera cannot determine the focus distance.

6. Turn the control dial to **OFF** when you are finished taking pictures.

TAKING PICTURES UNDERWATER

This camera can be used to a depth of approximately 10m (33 ft.). Picture sharpness and flash range are affected by water clarity. Non-flash exposures taken underwater tend to appear bluish. For best results, use the flash and take pictures within 2m (6.6 ft.) of your subject. After returning to the surface, clean and dry the lens cover-glass before taking additional pictures.

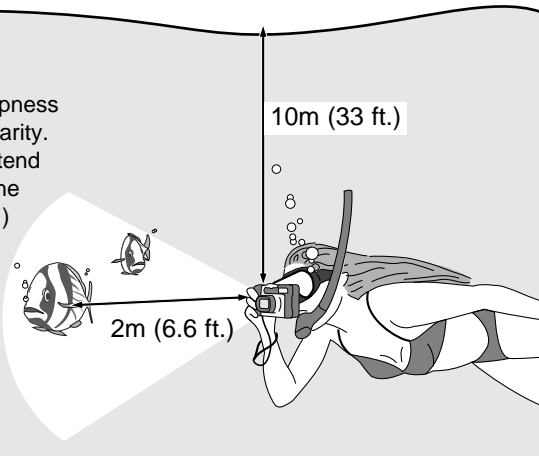

FOR CLOSER SUBJECTS

This camera's focus range is from 40cm to ∞ (1.4 ft. - ∞), 53cm to ∞ (1.75 ft. - ∞) underwater.

- The ready lamp blinks rapidly and the shutter locks when the subject is closer than 40cm.
- The ready lamp blinks slowly when the camera cannot determine the focus distance. Your subject may be out of focus.

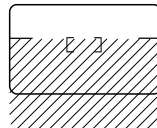

When your subject is closer than 1m (3.3 ft.), align the top of your image with the close-framing guides, using focus hold if necessary (see page 32).

Correct

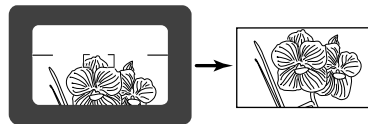

Not Correct

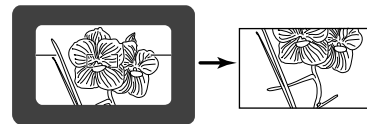

SPECIAL FOCUSING SITUATIONS

Some subjects or scenes, such as those described below, are difficult for the autofocus system to detect. To ensure proper focus in these situations, first lock focus on another object at the same distance from you as your main subject, recompose, then press the shutter-release button all the way down to take the picture.



When a very bright or low contrast area fills the center of the viewfinder.

The ready lamp will blink slowly to warn you that focus may not be accurate.



When your subject is near a very bright object or area.

The ready lamp may glow, but the focus may not be accurate.

SPECIAL FOCUSING SITUATIONS



When two subjects overlap in the focus frame.

The ready lamp will glow, but the closer of the two subjects will be in focus.

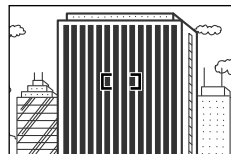

When a subject composed of alternating light and dark lines fills the center of the viewfinder.

The ready lamp will blink rapidly and the shutter will lock.

FOCUS HOLD



Subjects outside the focus frame may not be in focus. Use focus hold to ensure accurate focusing.

1. Center your subject in the focus frame.



FOCUS HOLD



2. Press and hold the shutter-release button partway down until the ready lamp glows.

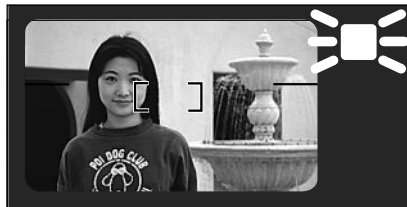

3. Without lifting your finger, recompose the picture and press the shutter-release button all-the-way down to take the picture.

- Lift your finger from the shutter-release button to cancel focus hold.

USING THE BUILT-IN FLASH

Autoflash mode is set when the control dial is turned to **AUTO**, the flash will fire automatically in low-light situations.

Ready Lamp

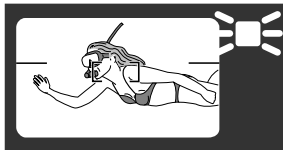

Wait until the ready lamp glows, then take the picture.

- The flash takes approximately 5 seconds to charge.

- The ready lamp blinks rapidly and the shutter locks when the subject is closer than 40 cm.
- The ready lamp blinks slowly when the camera cannot determine the focus distance. Your subject may be out of focus.

USING THE BUILT-IN FLASH

Flash Range

The range of the built-in flash depends on the film speed and the focal length you are using. To ensure proper exposure, make sure your subject is positioned within the flash range.

Note: The following flash ranges are for surface photography only.

Stay within 2m (6.6 ft.) of your subject when taking pictures underwater.

Focal Length	ISO 100	ISO 200	ISO 400
WIDE	0.55~3.6m (1.8~11.8 ft.)	0.55~5.1 m (1.8~16.7 ft.)	0.73~7.2m (2.4~23.6 ft.)
TELE	0.40~2.3m (1.3~7.5 ft.)	0.40~3.2 m (1.3~10.5 ft.)	0.45~4.5m (1.5~14.8 ft.)

USING THE BUILT-IN FLASH

Red-Eye Reduction

When photographing people or animals at night or other low-light situations, light reflecting off the inside of the subject's eyes may produce the effect called red-eye. Use red-eye-reduction to reduce the red-eye effect.

Turn the control dial to .

- Warn your subject(s) that the red-eye-reduction lamp on the front of the camera will illuminate before the picture is taken.

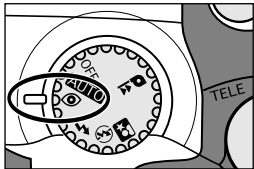

USING THE BUILT-IN FLASH

Manual Fill-Flash

The flash will fire when the shutter is released regardless of lighting. Use manual fill-flash to illuminate a backlit subject or to reduce harsh shadows on your subject's face.

Turn the control dial to .

Flash Cancel

Use flash cancel when photographing twilight scenes or to capture the ambiance of existing light.

Turn the control dial to .

- The shutter speed may be slow when the flash is cancelled. Use of a tripod is recommended.

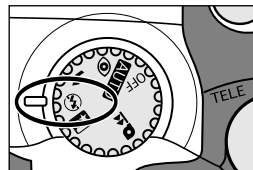
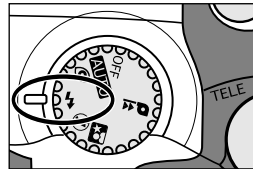

USING THE BUILT-IN FLASH

Night Portrait

Night-portrait mode balances the flash and existing light exposure so you can take beautiful pictures of people at sunset or at night.

Turn the control dial to .

- The shutter speed will most likely be slow. Use of a tripod is recommended.

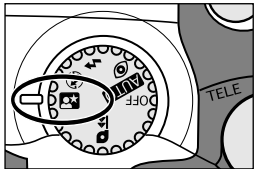



REWINDING THE FILM

Auto Rewind

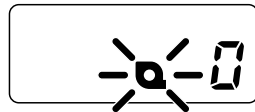
Your camera automatically rewinds the film into the cassette after the last exposure.



1. Wait for the film to completely rewind into the cassette.

- The frame counter will count down during rewind.
-  will appear and  blink in the data panel when the film is rewound.

2. Lift the film-chamber release and turn it to OPEN.

- Before opening the film-chamber door, wipe any dirt or moisture off of the camera.

3. Open the film-chamber door and remove the film.

- The film's current VEI indicator will be .

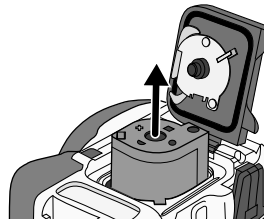

REWINDING THE FILM

Manual Rewind

Use manual rewind when you want to remove the film before exposing the last frame.

Note: Film cannot be reloaded after it has been rewound.

1. Turn the control dial to **Q**.
2. Press the date/select and self-timer/adjust buttons at the same time.
 - The camera will start to rewind the film.
3. Follow steps 1 - 3 from automatic rewind.

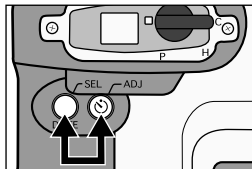

DATE IMPRINTING

Your camera uses the film's magnetic data strip to record date and time information your photofinisher can imprint on the front and back of your photographs.

Note: Some labs can not imprint on the front of your photographs. See your photofinisher for a full description of available services.

Imprinting the Date or Time

Before taking the picture:

Press the date/select button until the data you want printed on the front of the print appears in the data panel.

- The sequence is: DATE → TIME → -- -- -- (no imprinting).
- The selected date/time mode will remain on until another mode is selected.
- When -- -- -- is displayed in the data panel, no data will be printed on the front of the print, but the date and time of the exposure will be imprinted on the back of the print.



DATE IMPRINTING

Setting the Date and Time

- This camera has an automatic calendar through the year 2030.

1. Turn the control dial to **AUTO**.

2. Press and hold the date/select button until the year blinks in the data panel.

- Only the date will be displayed in the data panel.

3. Press the self-timer/adjust button to change the blinking item.

- Press and hold the self-timer/adjust button to change the value rapidly.

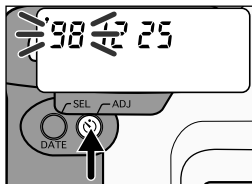
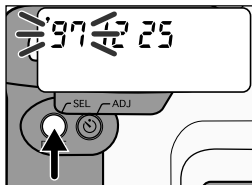

DATE IMPRINTING

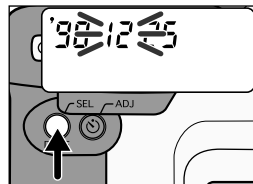

4. Press the date/select button to choose the next item to adjust.

- The sequence is `YY → MM → DD → HH → MM.
- Time is displayed and imprinted in 24-hour format.

5. Repeat steps 3 and 4 until all items in the date/time display are correct.

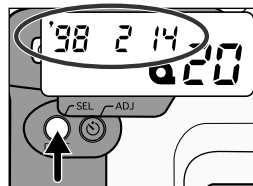

6. Press the date/select button until all items in the data panel stop blinking.

DATE IMPRINTING

Changing the Date/Time Format

1. Turn the control dial to OFF.

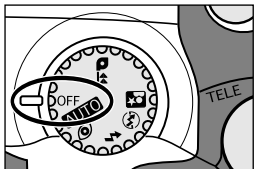

2. Press the date/select button until the date display blinks in the data panel.

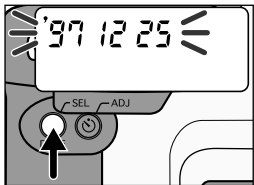

DATE IMPRINTING

3. Press the self-timer/adjust button to change the date format.

- The format sequence is `Y M D → M D`Y → D M`Y.

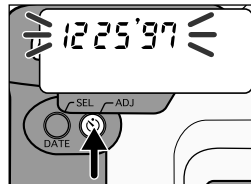

4. Press the date/select button until all items in the data panel stop blinking.

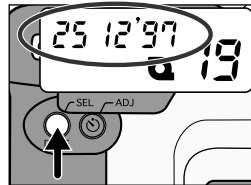

SELF TIMER

The self-timer delays release of the shutter for approximately ten seconds.

1. Mount the camera on a tripod or the optional handy tripod (not included) and place on a level surface.

2. Press the self-timer/adjust button.

-  will appear in the data panel.



Shown with optional
Handy Tripod.

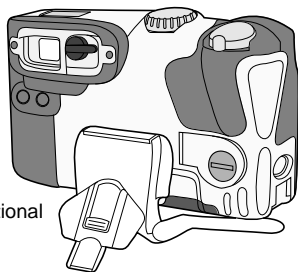

SELF TIMER



3. Frame your subject(s) in the viewfinder.

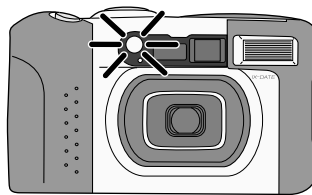

4. Press the shutter-release button all-the-way down to take the picture.

- The self-timer lamp blinks until the shutter releases.
- The self-timer is automatically cancelled after the shutter releases or the camera is turned off.
- To cancel the self-timer before the picture is taken, press the self-timer button again or turn the camera off.

CARING FOR YOUR CAMERA

Cleaning

- If the camera body is dirty, wipe it clean with a soft, dry cloth.
- After using the camera in or near salt water, clean it by immersing it in a small volume of fresh water, then wipe it dry with a soft cloth.
- To clean the lens cover glass, brush away any dust or sand. If necessary, moisten a lens tissue with lens cleaning fluid and gently wipe the cover glass in a circular motion.
- Do not hold the camera under running water.
- Never use alcohol or solvents to clean the camera.
- Remove foreign matter from the gaskets and joining surfaces with a clean dry cloth when the film and battery chambers are opened.

Before Important Events

- Check camera operation carefully or take test photographs.
- Minolta is not responsible for any loss that may occur due to an equipment malfunction.

CARING FOR YOUR CAMERA

Storage

When storing the camera for extended periods,

- Store the camera in a cool, dry, well-ventilated area away from dust and chemicals. For longer periods, place the camera in an airtight container with a silica gel drying agent.
- Before using after prolonged storage, check the camera's operation to make sure it's functioning properly.

Questions and Service

- If you have questions about your camera, contact your local camera dealer or write to the Minolta distributor in your area.
- Before shipping your camera for repair, contact an authorized Minolta Service Facility for details.



Take your film to a photolab displaying the Advanced Photo System logo to receive the best possible prints. Photofinishers displaying this logo have been certified according to Advanced Photo System guidelines.

1. **CHP - Print Format**

Your film will be printed according to the format set when the picture was taken.

2. **Date Imprinting**

The date and time are printed on the back of the picture in the chosen format.

3. **PQI - Print Quality Improvement**

The lab will compensate (or not compensate) printing according to the data recorded on the magnetic data strips.

4. **Film is returned in the cassette.**

To keep the film dust free and aid in organization, film is returned in its original cassette. The VEI will be set to ■ to prevent accidental loading.

5. **Index Print**

An index print showing a numbered image of each frame is included with your returned order.

REPRINTS

Images are always captured in the H Print format. However, any of the three formats can be selected when ordering reprints.

SPECIFICATIONS

Camera Type:	Water resistant IX240 Lens Shutter Type
Lens:	30 - 50mm f/4.0 – 6.4 (approx. 38 - 63mm in the 35mm format)
Viewfinder Magnification:	0.44 - 0.67X
Focusing Range:	0.4m – ∞ (1.4 ft. - ∞) Underwater: 0.53m - ∞ (1.75 ft. - ∞)
Exposure:	Programmed AE
Film Speed Range:	100 - 3200 ISO
Metering Range (ISO 200):	Wide: EV 6 - 16, Tele: EV 7.4 - 16
Flash Range (ISO 200):	Wide: 0.55 ~ 5.1m (1.8 ~ 16.7 ft.), Tele: 0.4 ~ 3.2m (1.3 ~ 10.5 ft.)
Battery:	One CR2 3V lithium battery
Battery performance:	Approximately ten 25-exposure rolls (Based on Minolta's standard test method with the flash on for 50% of the exposures.)
Underwater Performance:	Tested by Minolta to be submersible to a depth of approx. 10m (33 ft.).
Dimensions:	128 x 74.5 x 66 mm (5.0 x 2.9 x 2.6 in.)
Weight (w/o battery):	340g (12 oz.)

Specifications and accessories are based on the latest information available at the time of printing and are subject to change without notice.

This device complies with Part 15 of the FCC Rules. Operation is subject to the following two conditions: (1) This device may not cause harmful interference, and (2) this device must accept any interference received, including interference that may cause undesired operation. Changes or modifications not approved by the party responsible for compliance could void the user's authority to operate the equipment. This equipment has been tested and found to comply with the limits for a Class B digital device, pursuant to Part 15 of the FCC Rules. These limits are designed to provide reasonable protection against harmful interference in a residential installation. This equipment generates, uses and can radiate radio frequency energy and, if not installed and used in accordance with the instructions, may cause harmful interference to radio communications. However, there is no guarantee that interference will not occur in a particular installation. If this equipment does cause harmful interference to radio or television reception, which can be determined by turning the equipment off and on, the user is encouraged to try to correct the interference by one or more of the following measures:

- Reorient or relocate the receiving antenna.
- Increase the separation between the equipment and the receiver.
- Connect the equipment to an outlet on a circuit different from that to which the receiver is connected.
- Consult the dealer or an experienced radio/TV technician for help.

This Class B digital apparatus meets all requirements of the Canadian Interference-Causing Equipment Regulations.



This mark on the bottom of your camera certifies that this camera meets the requirements of the EU (European Union) concerning interference causing equipment regulations. CE stands for Conformité Européenne (European Conformity).

Minolta Co., Ltd.

Minolta GmbH

Minolta France S.A.

Minolta (UK) Limited

Minolta Austria Ges. m.b.H.

Minolta Camera Benelux B.V.

Belgium Branch

Minolta (Schweiz) AG

Minolta Svenska AB

Finland Branch

Minolta Portugal Limitada

Minolta Corporation

Head Office

Los Angeles Branch

Minolta Canada Inc.

Head Office

Vancouver Branch

Minolta Hong Kong Limited

Minolta Singapore (Pte) Ltd.

Shanghai Minolta Optical

Products Co., Ltd.

3-13, 2-Chome, Azuchi-Machi, Chuo-Ku, Osaka 541, Japan

Kurt-Fischer-Strasse 50, D-22923 Ahrensburg, Germany

365 Route de Saint-Germain, F-78420 Carrières-Sur-Seine, France

Rooksley Park, Precedent Drive, Rooksley, Milton Keynes, MK13 8HF, England

Amalienstrasse 59-61, A-1131 Wien, Austria

Zonnebaan 39, P.O. Box 6000, NL-3600 HA Maarssen, The Netherlands

Kontichsesteenweg 38, B-2630 Aartselaar, Belgium

Riedstrasse 6, CH-8953 Dietikon, Switzerland

P.O.Box 9058, Albygatan 114, S-17109 Solna, Sweden

Niittykatu 6 PL 37, SF-02201 Espoo, Finland

Av. do Brasil 33-A, P-1700 Lisboa, Portugal

101 Williams Drive, Ramsey, New Jersey 07446, U.S.A.

11150 Hope Street Cypress, CA 90630, U.S.A.

369 Britannia Road East, Mississauga, Ontario L4Z 2H5, Canada

230-3771 Jacombs Road, Richmond, B.C. V6V 2L9, Canada

Room 208, 2/F, Eastern Center, 1065 King's Road, Quarry Bay, Hong Kong, China

10, Teban Gardens Crescent, Singapore 608923

368 Minolta Road, Songjiang, Shanghai, China